



PST/PST-A/-SS/-ASS Loadcell

PST/PST-A/-SS/-ASS



20~1000kg

1.2~10t

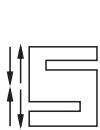
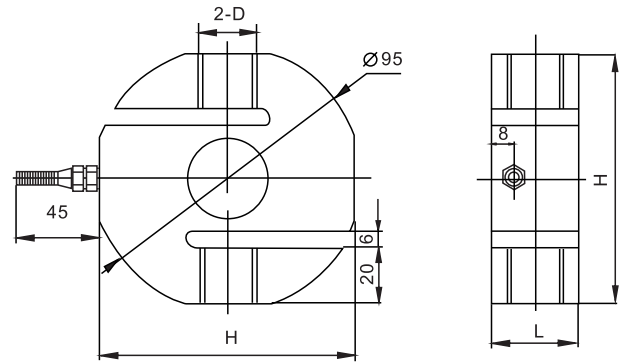
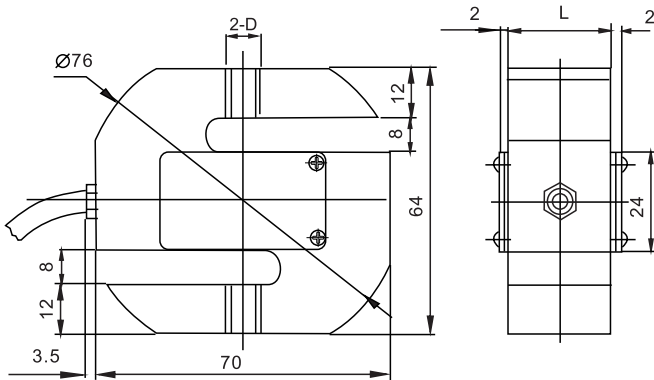

Rated Load (kg)	D	L
20~150	M8	12
200~500	M12	20
700~1000	M12	25

Rated Load (t)	D(mm)	L(mm)	H
1.2~5	M20	32	90
7.5	M24	40	90
10	M30x2	50	110

Crane scale,blending scale,packing scale, electromechanical scale,special testing device

TECHNICAL PARAMETER

OAP version 4Wires:Exc+(Blue);Exc-(Black);Sig+(White);Sig-(Red)

Rated capacities(Emax)	20,30,50,75,100,150,200,250,300,500,700,1000kg; 1.2,1.5,2,2.5,3.5,7.5,10t	Temperature range, compensated	-10℃~+40℃
		Temperature range, operating	-30~+70℃
Sensitivity	2.0±0.003mV/V (20kg~7.5t) ; 1.8±0.002mV/V (10t)	Maximum safe overload	120%F.S
Accuracy class	C2~C3	Ultimate overload	200%F.S
		Excitation,recommended	10~12V DC
Zero balance	±1%F.S	Excitation,maximum	15V DC
TC ZERO	±0.02%F.S/10℃	Protection class	IP65 (20~100kg); IP68 (1.2~10t)
TC SPAN	±0.02%F.S/10℃	Construction	Alloy Steel Stainless Steel
Input resistance	400±20Ω(200~300kg,1.2~10t)	Cable	Length:2.6m(20~1000kg),3m(1.2~10t)
Output resistance	352±3Ω		Diameter: φ 5mm(20~1000kg,10t), φ 6mm(1.2~7.5t)
Insulation resistance	≥5000MΩ		